

Full-key Macro Definition Backlight Game Keyboard Series

K201 Datasheet

USB Game Keyboard IC

Version 1.00

Table of contents

1. General Description	1
2. Feature	1
3. Block Diagram	1
4. Package	2
4.1 Pin Assignment	2
4.2 Pin Definition	2
5. Application Note	3
5.1 Keyboard and Keyboard Indicator lamp	3
5.1.1 Keyboard Array	3
5.1.2 Keyboard Array Function	4
5.1.3 Num, Scroll, Caps, WinLck/Game	5
5.1.4 Typical 26-key non-punching Keyboard Array	6
5.1.5 Typical 87 keyboard Array	6
5.1.6 Typical 104 keyboard Array	7
5.2 Backlight LED	7
5.2.1 ModeOpt Note	7
5.2.2 Illustration of Lamp Type	7
5.2.3 Brilliant Backlight Mode	8
5.2.4 Synchronous Backlight Mode	9
5.2.5 Reaction Mode	9
5.2.6 Backlight Control Method	10
5.3 Fn Composite Key Function	11
5.4 Encoder	12
5.5 Configuration and macro definition storage	12
6. Electrical Characteristics	14
6.1 Absolute Maximum Rating	14
6.2 DC Electrical Characteristic(VDD = 5.0V, Temperature = 25°C)	14
7. Typical Application Circuit	15
7.1 Typical Application Circuit	15
7.2 Keyboard Array Circuit	16
8. Pin Location	17

9. Typical Application PCB and Bonding	17
9.1 Typical Application PCB	17
10. Revision History.....	18

1. General Description

K201 is a fully customized multi-mode backlight USB storage macro definition game keyboard chip. The chip can support up to 160 keys, and the function of keyboard array can be modified at will. Fn+F1~F12 combination key function can be customized according to user needs (multimedia, full-key locking, etc.).K201 also supports the function of encoder, which can be customized as volume (+), mouse up and down roll, macro and other functions.

In the application of backlight, K201 has its own characteristics. It supports two types of backlight, which are selected according customer choice.

1) Adaptive type of RGB lamp, automatic judgment of light primary color(R/RG/RGB lamp), to achieve a variety of color changes (monochrome/trichrome/seven color). At the same time, five backlight modes are supported under seven colors.

2) Three single-line flashlight types, each of which has 9 backlight modes (including synchronization, flashing backlight mode and reaction mode). The combination keys Fn + Scr switch backlight mode, Fn + Ins switch color and so on are supported in both lamp types.

K201 can use I2C interface to extend EEPROM of 4kb~128kb. It has large storage space and can burn millions of times without losing power-off data. Support storage macro definition, up to 8 keyboard macros and 2 encoder macros (clockwise and counterclockwise). The macro is defined as the combination of keyboard and mouse functions. Backlight mode and GPIO control buzzer (or vibration motor) can be added to the macro to realize the integration of keyboard combination, backlight, sound (or vibration). Keyboard configuration and macro definition are stored in EEPROM by driver/burner burning.

Keyboard has two modes: normal mode and game mode. In general mode, the function of standard keyboard (such as 87 keyboard, 104 keyboard, etc.) is used, and the factory configuration does not need to be modified repeatedly. In game mode, the function of any keyboard key in the array is modified by driver/burner program, such as keyboard, multimedia, special function, macro definition, etc. Common mode and game mode can be switched at any time by combining keys Fn + M.

It has a built-in LED driver and internal oscillator to minimize the external components.

2. Feature

- Up to 160 keys, the keyboard function array can be customized
- Keyboard arrays support full-key non-punching and are compatible with 26-Key non-punching
- Keyboard Key Conflict Detection
- Compliant with USB2.0 and USB HID Specification V1.1.
- Supports different versions of Windows, MAC OS, Linux systems; Drivers and burners only support Windows systems, which can be used in other systems after configuration
- Full key and coder support macro definition, driver interface macro recording, up to 8 keyboard macros and 2 encoder macros
- Extensible 4 kb~128kb EEPROM, large storage space, and millions of Burning Times
- Supports two types of lighting: RGB adaptive light, three-way single-line dazzling light; realizes a variety of backlight modes, supports reaction, synchronization and dazzling backlight modes
- Backlight color can be customized to support 16.8 million colors
- Adaptive type of RGB lamp, automatic recognition of monochrome, trichrome and seven-color lamp
- Fn+F1~F12 combination key function can be customized (multimedia, full key lock, etc.)
- Encoder adjusts volume and can customize function
- Support GPIO control buzzer/vibration motor etc. (macro key trigger)
- It has a built-in LED driver and internal oscillator to minimize the external components.

Typical applications: ordinary mechanical keyboard, light-emitting mechanical keyboard, game keyboard, etc

3. Block Diagram

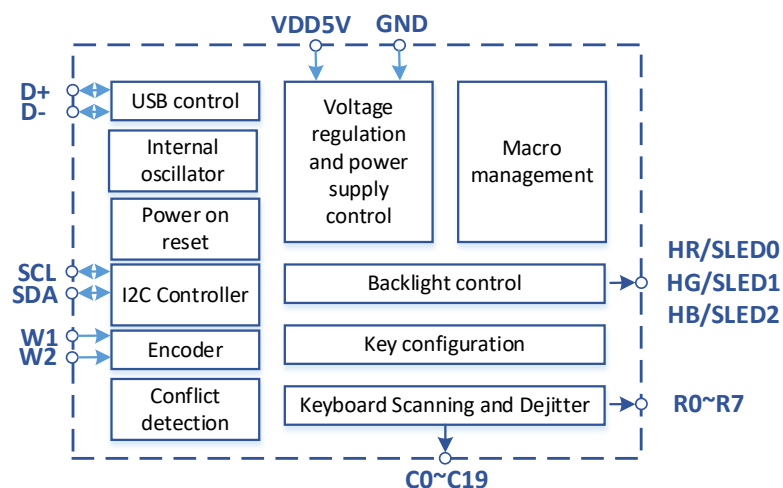

Figure 3-1 Block Diagram

4. Package

4.1 Pin Assignment

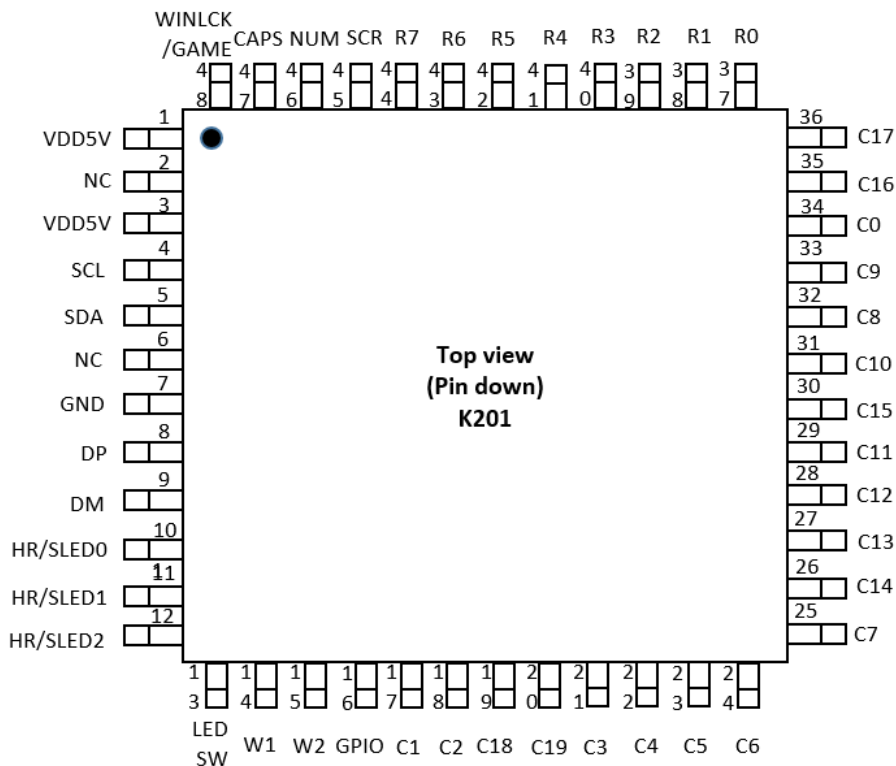

Figure 4-1. Pin Assignment

4.2 Pin Definition

Pin No.	Pin Name	Type	Function description
1,3	VDD5V	POWER	5V power input
2, 6	NC	NC	Undefined
4	SCL	IN/OUT	EEPROM 的 I2C Interface
4	SDA	IN/OUT	EEPROM 的 I2C Interface
7	GND	GROUND	GROUND
8	DM	IN/OUT	USB D-
9	DP	IN/OUT	USB D+
10	HB/SLED2	OUT	Primary blue output or single-line flashlight signal
11	HG/SLED1	OUT	Primary green output or single-line flashlight signal
12	HR/SLED0	OUT	Primary red output or single-line flashlight signal
13	LED_SW	OUT	Backlight power control signal

14	W1	IN	Volume Encoder Input
15	W2	IN	Volume Encoder Input
16	GPIO	OUT	GPIO control signal
17~36	C0~C19	OUT	Keyboard Scanning Output
37~44	R0~R7	IN	Keyboard Scanning Input
45	SCR	OUT	Scroll Lock indicator light
46	NUM	OUT	Num Lock indicator light
47	CAPS	OUT	Caps Lock indicator light
48	WINLCK/GAME	OUT	Win Lock or game mode indicator light

Table 4-1 Pin definition

5. Application Note

5.1 Keyboard and Keyboard Indicator lamp

5.1.1 Keyboard Array

	R0	R1	R2	R3	R4	R5	R6	R7
C0	K0	K1	K2	K3	K4	K5	K6	K7
C1	K8	K9	K10	K11	K12	K13	K14	K15
C2	K16	K17	K18	K19	K20	K21	K22	K23
C3	K24	K25	K26	K27	K28	K29	K30	K31
C4	K32	K33	K34	K35	K36	K37	K38	K39
C5	K40	K41	K42	K43	K44	K45	K46	K47
C6	K48	K49	K50	K51	K52	K53	K54	K55
C7	K56	K57	K58	K59	K60	K61	K62	K63
C8	K64	K65	K66	K67	K68	K69	K70	K71
C9	K72	K73	K74	K75	K76	K77	K78	K79
C10	K80	K81	K82	K83	K84	K85	K86	K87
C11	K88	K89	K90	K91	K92	K93	K94	K95
C12	K96	K97	K98	K99	K100	K101	K102	K103
C13	K104	K105	K106	K107	K108	K109	K110	K111
C14	K112	K113	K114	K115	K116	K117	K118	K119
C15	K120	K121	K122	K123	K124	K125	K126	K127
C16	K128	K129	K130	K131	K132	K133	K134	K135
C17	K136	K137	K138	K139	K140	K141	K142	K143
C18	K144	K145	K146	K147	K148	K149	K150	K151
C19	K152	K153	K154	K155	K156	K157	K158	K159

Figure 5-1 Keyboard Array

The 160 key functions in the keyboard array can be defined arbitrarily and highly compatible with different mechanical keyboard arrays. If compatible thin film keyboard arrays row R0 ~ R7, column C0 ~ C17, then C18 ~ C19 hangs, other keyboard arrays can be set according to the function of mechanical keyboard arrays.

Keyboard arrays can achieve up to full-key without punching, or 26 keys without punching, etc. The non-punching area can be set according to the keyboard array. 19 keys in any column can be selected, and the other 7 keys in the row where the keys are not selected. The gray area shown in Table 5-1 can be a 26-Key non-punching area. There are many combinations of non-punching areas. Placing common keys in the non-punching area can ensure that multiple keys can be pressed at the same time.

5.1.2 Keyboard Array Function

Keyboard array function has two modes: normal mode and game mode. Among them, the general mode can define all keys as keyboard, multimedia, special function keyboard, which is used as standard 101, 104 keyboard, factory configuration, without repeated modification; the game mode can modify all keys as keyboard, multimedia, special function, game macro and so on through the driver. The game macro is defined as a combination of keyboard and mouse functions, including keyboard and mouse keys and mouse displacement, which can modify the game scene parameters (such as ballistic parameters in gunfight games). The combination key Fn+R can reset from game mode to normal mode, and Fn+M can switch from normal mode to game mode. Keyboard mode switching can choose whether to store the switched mode in memory in real time. There are many factors to consider in making keyboard array function, such as system, game, software and other commonly used combination keys. It is easy for keyboard conflicts to cause some combination keys function failure. In practical use, the commonly used keyboard arrays can be selected as common mode functions.

Type	Function
Keyboard	A-Z/F1-F12/0-9/Shift/Ctrl/Alt/Win……
Special function	KeyPad(0 0)/KeyPad(0 0 0)/Boss/¥/€/LedBrt+/LedBrt-/LedSpd+/LedSpd-/LedMode /KeyExchg/WinLck/KeyLck/LedOnOff/LedColor/KbdModeChg/KeyLck/KbdModeRst/Fn/NoFunc
Multimedia	MyComputer/Play/Pause/Media/Mute/CD Stop/WWWBack/WWWForward/WWWStop/ WWWSearch/Rec/Calculator/WWWHome/PreTrack/NextTrack/Vol+/Vol-/WWWRefresh/WWWFavorite
System function	Power/Sleep/Wakeup
Game Macro (Game Mode)	Keyboard, mouse, backlight mode, GPIO, delay, etc Such as: Jedi Survival (Support for Pressure Gun), Heroic Alliance, Anti-war, Crossing the Fire Line……

Note: Game macros are generally not supported in normal mode, such as keyboards with special requirements (keyboards with extra macro buttons) can be used for open use

Figure 5-2 Keyboard Array Function

5.1.3 Num, Scroll, Caps, WinLck/Game

K201 has three standard indicators. The corresponding button operations of Num, Scroll, and Caps indicate the corresponding status. The WinLck/Game indicator can be factory configured to the desired indicator function via the programming program. After being configured as a WinLck light, WinLck indicator lights up after the combination of the Fn+Win-L key and the Win key. Otherwise, it is off. After being configured as a Game light, the Game light is on after the keyboard is switched to the game mode; the normal mode Game light is off.

5.1.4 Typical 26-key non-punching Keyboard Array

	R0	R1	R2	R3	R4	R5	R6	R7
C0	Tab	~	F7	Y	End	7&	::	ledSpd+
C1	Caps	M2	M3	M4	M5	M6	M7	M8
C2	X	2@	MyComputer	Play/Pause	Media	Shift-R	Mute	CD Stop
C3	F	F1	F5	WWWBack	KeyLck	WWWForward	WWWStop	WWWSearch
C4	Shift-L	U	F6	F2	WinLck	Enter-L	LedMode	LedColor
C5	Ctrl-L	K	P	LedBrt+	LedBrt-	KeyExchg	Esc	Mail
C6	APP	G	↑	←	↓	M	Alt-L	→
C7	T	F3	M1	KeyPad(-)	KeyPad(+)	K107	KeyPad(Ent)	Rec
C8	D	=+	F9	LedOnOff	}]	9('"	Fn
C9	S	-_	F8	4\$	[{	8*	Insert	N
C10	W	BackSpace	F11	PrintScr	Home	Del	H	.>
C11	Q	J	F10	K14	\	0)	PageDown	,<
C12	B	KeyPad(0 0)	KeyPad(0 0 0)	NumLck	KeyPad(7)	KeyPad(4)	KeyPad(1)	LedSpd-
C13	V	5%	Boss	KeyPad(/)	KeyPad(8)	KeyPad(5)	KeyPad(2)	KeyPad(0)
C14	R	6^	¥	KeyPad(*)	KeyPad(9)	KeyPad(6)	KeyPad(3)	KeyPad(.)
C15	E	L	F12	ScrollLck	Pause	PageUp	K42	/?
C16	A	F4	O	Calculator	K45	K150	K151	Win-R
C17	Space	I	K56	Win-L	WWWHome	N-Chg	Chg	Roma
C18	Z	1!	Power	PreTrack	ALT-R	NextTrack	Sleep	WakeUp
C19	C	3#	€	Vol+	Vol-	WWWRefresh	Ctrl-R	WWWFavorite

Note: ①26-key non-punching is shown in the grey area:Tab、Caps、X、F、Shift-L、Ctrl-L、G、↑、←、↓、M、Alt-L、→、T、D、S、W、Q、B、V、R、E、A、Space、Z、C

②M1~M8 define keys for macros

③Red fonts are special function keys:KeyPad (0 0) 、KeyPad(0 0 0)、Boss、¥、€、LedBrt+、LedBrt-、LedSpd+、LedSpd-、LedMode、KeyExchg、WinLck、KeyLck、LedOnOff、LedColor

④When EEPROM is not programmed, this array is used as the keyboard array function by default in the chip

Figure 5-3 Typical 26-key non-punching Keyboard Array

5.1.5 Typical 87 keyboard Array

	R0	R1	R2	R3	R4	R5	R6	R7
C0	Tab	~	F7	Y	End	7&	::	
C1	Caps							
C2	X	2@				Shift-R		
C3	F	F1	F5					
C4	Shift-L	U	F6	F2		Enter-L		
C5	Ctrl-L	K	P				Esc	
C6	APP	G	↑	←	↓	M	Alt-L	→
C7	T	F3						
C8	D	=+	F9		}]	9('"	Fn
C9	S	-	F8	4\$	[{	8*	Insert	N
C10	W	BackSpace	F11	PrintScr	Home	Del	H	.>
C11	Q	J	F10		\	0)	PageDown	,<
C12	B							
C13	V	5%						
C14	R	6^						
C15	E	L	F12	ScrollLck	Pause	PageUp		/?
C16	A	F4	O					
C17	Space	I		Win-L				
C18	Z	1!			ALT-R			
C19	C	3#					Ctrl-R	

Figure 5-4 Typical 87 keyboard arrays

5.1.6 Typical 104 keyboard Array

	R0	R1	R2	R3	R4	R5	R6	R7
C0	Tab	~	F7	Y	End	7&	::	
C1	Caps							
C2	X	2@				Shift-R		
C3	F	F1	F5					
C4	Shift-L	U	F6	F2		Enter-L		
C5	Ctrl-L	K	P				Esc	
C6	APP	G	↑	←	↓	M	Alt-L	→
C7	T	F3		KeyPad(-)	KeyPad(+)		KeyPad(Ent)	
C8	D	=+	F9		}]	9(" "	Fn
C9	S	-	F8	4\$	[{	8*	Insert	N
C10	W	BackSpace	F11	PrintScr	Home	Del	H	.>
C11	Q	J	F10		\	0)	PageDown	,<
C12	B			NumLck	KeyPad(7)	KeyPad(4)	KeyPad(1)	
C13	V	5%		KeyPad(/)	KeyPad(8)	KeyPad(5)	KeyPad(2)	KeyPad(0)
C14	R	6^		KeyPad(*)	KeyPad(9)	KeyPad(6)	KeyPad(3)	KeyPad(.)
C15	E	L	F12	ScrollLck	Pause	PageUp		/?
C16	A	F4	O					
C17	Space	I		Win-L				
C18	Z	1!			ALT-R			
C19	C	3#					Ctrl-R	

Figure 5-5 Typical 87 keyboard Array

5.2 Backlight LED

5.2.1 ModeOpt Note

There are two options for choosing the lighting type of keyboard by ModeOpt. [See Table 5-6 for details.).

ModeOpt	Light Type
GND	Three-way single-line dazzling lights
HI-Z	RGB Lamp Adaptation

Table 5-6 ModeOpt Note

5.2.2 Illustration of Lamp Type

Two lamp types are supported: RGB adaptive lamp and three-way single-line dazzling lamp (see Table 5-6 for details). The adaptive type of RGB lamp can automatically judge whether it is monochrome, two primary colors or three primary colors, and drive the three primary colors of RGB lamp by "HR/HG/HB". Support synchronous backlight mode and reaction mode. There are three "SLED0/SLED1/SLED2" signals output to the single-line flashlight. They all support the flashlight backlight mode, synchronous backlight mode and reaction mode. There are seven backlight colors. Among them, the "SLED0" backlight supports 16.8 million color choices, and the "SLED1/SLED2" supports seven default color choices (red/green/blue/yellow/pink/blue/white). The default backlight

mode of power-on when the chip is out of the factory is selected by burning program/burner. Users can switch backlight mode by driver or combination key Fn+SCR, and store it in non-volatile memory EEPROM in real time.

5.2.3 Brilliant Backlight Mode

Only single-line flashlight support. Table 5-7 describes the backlight mode and its flow characteristics, mainly symmetry and flow direction, as well as backlight color customization.

Backlight Mode		M-Color	S-Color	Comet-Tail	Ambilight
Asymmetry	Positive	√	√	√	√
	Reverse	√	√	√	√
	Two-Way	√	√	√	
	Two-Way Changing Color	√			
Symmetry	Positive	√	√	√	√
	Reverse	√	√	√	√
	Two-Way	√	√	√	
	Two-Way Changing Color	√			
Backlight Color Customize		√	√	√	

Note: ① √ indicates support for this direction

② Only SLED0 supports 16.8 million Color, SLED1/SLED2 supports seven color customizations

Table 5-7 Brilliant Backlight Mode

5.2.4 Synchronous Backlight Mode

Backlight Mode		Breathing	Constantly Bright	Neon	Mute
Brilliant Lamp		Seven species 16.8 million color customization	Seven species 16.8 million color customization	√	√
RGB Lamp	RGB primary color	Seven species 16.8 million color customization	Seven species 16.8 million color customization	√	√
	RB primary color	Three species Blue/Red/Pink	Three species Blue/Red/Pink	√	
	RG primary color	Three species Green/Red/Yellow	Three species Green/Red/Yellow	√	
	GB primary color	Three species Blue/Green/Cyan	Three species Blue/Green/Cyan	√	
	Single Color	One Species	One Species	√	

Note: √ indicates support for this function, Automatically Judging the Use of Primary Colors under the adaptive Type of RGB Lamp

Table 5-8 Synchronous Backlight Mode

5.2.5 Reaction Mode

The default backlight is turned off. When the button is pressed, the corresponding backlight mode will be executed for a period of time before the light is turned off. The RGB lamp only supports the cyclic breathing as the response mode under the adaptive type; the backlight mode under the single-line flashlight type can be selected from four modes (cyclic breathing, single-lamp flowing water, cloud flowing water, comet tailing)

5.2.6 Backlight Control Method

- Users can set backlight mode, backlight color and so on through driver or burning program
- Combine keys Fn + Scr to switch lighting mode (excluding silence). Switching can be stored in real time and can customize the switched backlight mode
- Combination of keys Fn + Ins, switch the light color, such as breathing cycle, then cycle by cycle to switch monochrome, if bright, then switch monochrome by monochrome. Switches can be stored in real time and the number of colors can be customized
- Combination of keys Fn + PrtScr, switching lights on/off, from the light on, mute, light on (the previous mode), switching can be real-time storage.
- Combination button Fn+ ↑ ↓ , adjust backlight brightness under constant light (8 gears)
- Combination keys Fn+←→,adjust backlight speed in other backlight modes (6 gears)
- Combination button Fn + L, in the single-line dazzling lights, if more than one dazzling lights, switch the current configuration of the light. The current light will flicker white for a period of time and then recover. At this time, other key combinations (Fn + Scr / Fn + Ins / Fn + PrtScr) will configure the current one-way light
- The Brilliant backlight SLED0/SLED1/SLED2 supports 1-16 single-line serial lamps in each circuit. The number of lights can be customized by users according to their needs

5.3 Fn Composite Key Function

	Button	Function
Fn+	F1~F12	Ordinary mode/game mode can be customized to multimedia/full-key locking, etc
	W	WASD and ↑ ← ↓ → exchange
	Win-L	Lock Win and App
	↑	Increase backlight brightness (8 gear)
	↓	Decrease backlight brightness (8 gear)
	←	Decrease backlight speed (6 gears)
	→	Increase backlight speed (6 gears)
	Scr	Switch backlight mode (Up to 8 species)
	Ins	Switch backlight color (Up to 7 species)
	PrtScr	Turn on/off backlight
	L	Backlight switching in current configuration (single-line brilliant lights only)
	R	Keyboard function reset to normal mode
M	Keyboard Function normal Mode/Game Mode Switching	

Note: Fn+F1~F12 Composite key function supports normal Mode/Game Mode, The functions of the two modes are different.

Table 5-9 Fn Composite key function

	Button	Function
Fn+	F1	Player
	F2	Volume-
	F3	Volume+
	F4	Mute
	F5	Next song (set)
	F6	Last song (set)
	F7	Play/pause
	F8	Stop
	F9	Browser
	F10	Mail

	F11	My computer
	F12	Full key Lock

Table 5-10 Un-programmed EEPROM Fn+F1~F12 composite key function

5.4 Encoder

Encoder can be rotated clockwise and counterclockwise. In normal mode and game mode, the functions of the two directions are different and can be customized.

	Function (Clockwise/counterclockwise)
Encoder	Volume+
	Volume-
	Scroll up
	Scroll down
	Increase Backlight Brightness (8 gear)
	Decrease backlight brightness (8 gear)
	Decrease backlight speed (6 gears)
	Increase backlight speed (6 gears)
	Lighting streams clockwise (single-line dazzling lights only)
	Lighting streams counterclockwise (single-line dazzling lights only)
	Macro definition

Table 5-11 Encoder function

5.5 Configuration and macro definition storage

The chip extends to use EEPROM as memory through I2C interface, supports 4 kb~128kb, and does not lose power-down data. The keyboard array function works with the default function (see Table 5-3 for details), and does not support storing macro definitions and configuration data. Some configuration data, such as factory configuration and general mode, are stored in EEPROM and recorded by burning program/burner at factory. These configuration values are not changed after factory burning. Users can modify macro definition, keyboard array function of game mode, backlight mode and other configurations by drive.

There are some real-time storage configurations in the keyboard, that is, some configuration

changes after the combination keys are pressed and stored in the memory in real time. The capacity selection of EEPROM depends on the size of macro definition, which can store up to 8 keyboard macros and 2 encoder macros. If there are no special requirements, EEPROM capacity selection of 16 KB can achieve the keyboard and all macro definition functions.

The macro definition includes keyboard, multimedia, mouse button, mouse displacement, delay, light mode (only supporting SLED0 branch single-line dazzling lights), GPIO (vibration motor/buzzer, etc.) to realize keyboard, mouse, multimedia functions, and can change backlight mode to provide vibration or sound effects.

The burning program/burner is used as a tool for factory production. Some data need not be modified after factory production. The function defined by factory burning includes the function defined by driving software [see Table 5-12 for details]

	Function
Burning Program/Burner	Factory function configuration (real-time storage switch / indicator function /Alt+F4 is disabled, etc.)、 Backlight mode, keyboard function (Normal mode/Game mode) 、 Fn+F1~F12 (Normal mode/Game mode) 、 Encoder (Normal mode/Game mode) 、 Macro definition (Game mode) 、 VID/PID etc.
Driving software	Partial out-of-factory function configuration (whether Alt+F4 is disabled, etc.) Backlight mode, keyboard function (Game mode) 、 Fn+F1~F12 (Game mode) 、 Encoder (Game mode) 、 Macro definition (Game mode) etc.

Table 5-12 Function define

6. Electrical Characteristics

6.1 Absolute Maximum Rating

Parameters	Symbol	Min	Max	Unit	Notes
Supply Voltage	V_{DD}	-0.5	5.5	V	
Operating Temperature	T_O	-20	70	°C	
Storage Temperature	T_S	-50	125	°C	
Lead Solder Temperature	T_{SOLDER}	-	260	°C	
Input Voltage	V_{in}	-0.5	5.5	V	
ESD	V_{ESD}	2		KV	All pins, human body model

6.2 DC Electrical Characteristic(VDD = 5.0V, Temperature = 25°C)

Parameter	Symbol	Min	Typical	Max	Units	Notes
Operating Voltage	V_{DD}	4.5	5	5.5	V	
Operating Current	I_{OP}	-	3.6	-	mA	$F_{osc}=48MHz$, excluding Backlight
Input Voltage High	V_{IH}	2	-	-	V	
Input Voltage Low	V_{IL}	-	-	0.8	V	
Output Voltage High	V_{OH}	2.8	-	3.6	V	
Output Voltage Low	V_{OL}	0	-	0.4	V	
LED Current (CAPS、NUM、SCR、 WINLCK/GAME)	I_{LED}	-	10	-	mA	

7. Typical Application Circuit

7.1 Typical Application Circuit

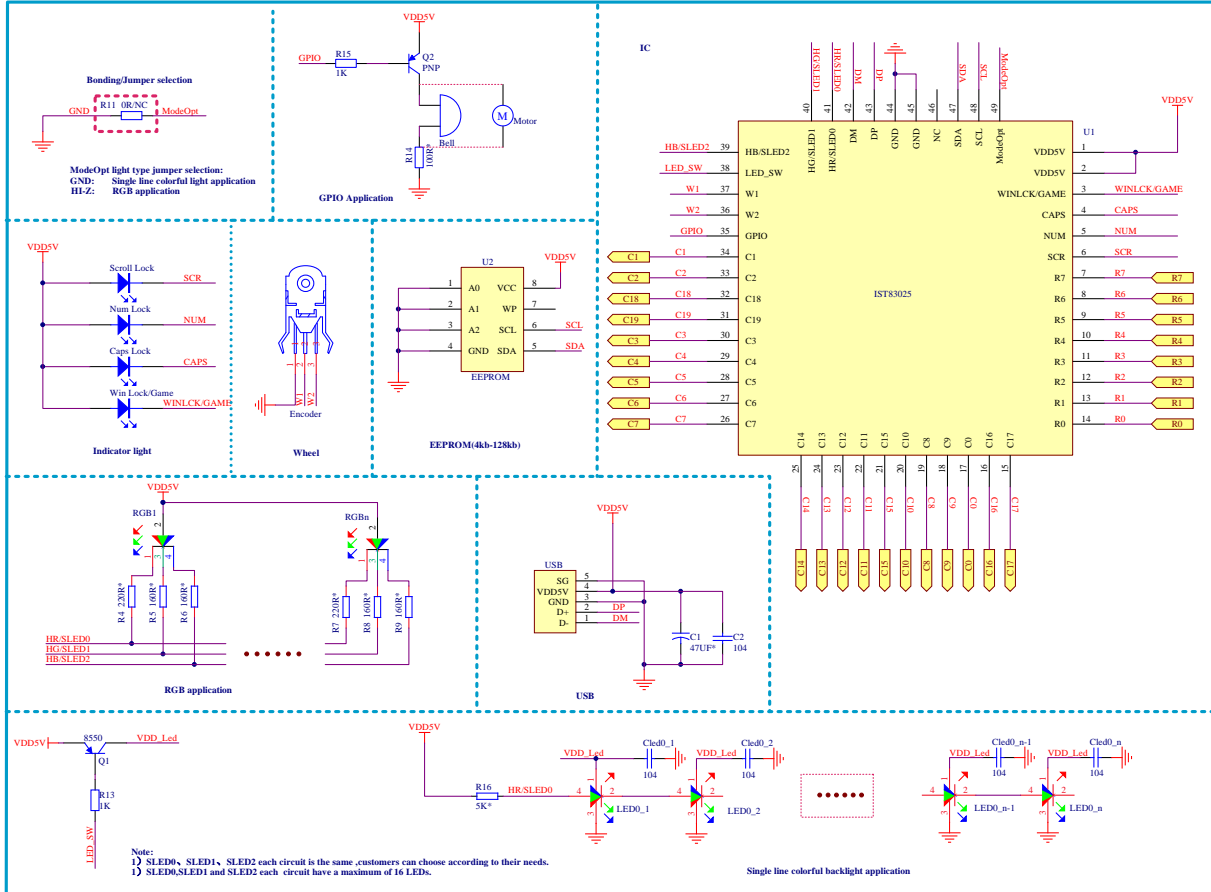

Figure 7-1 Typical Application Circuit

7.2 Keyboard Array Circuit

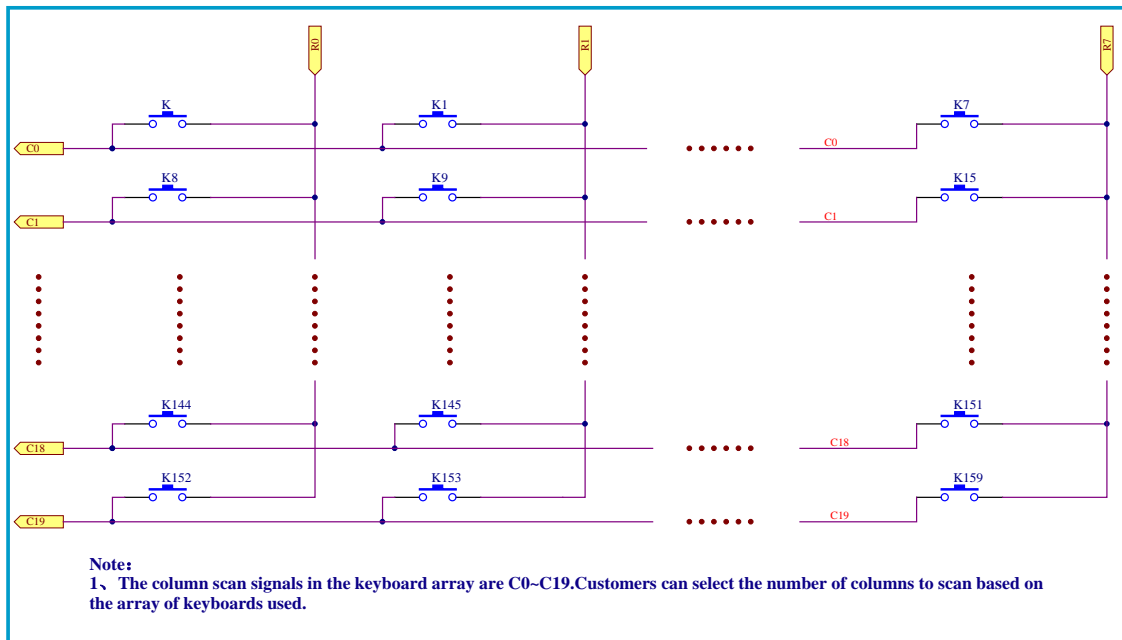

Figure 7-2. Keyboard Array Circuit

8. Pin Location

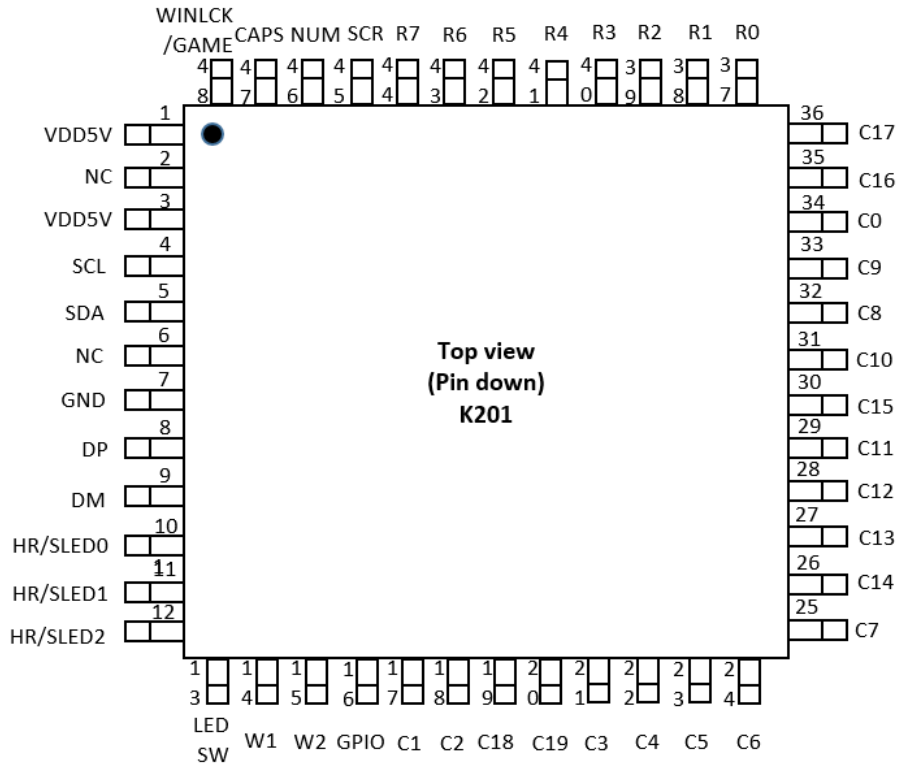

Figure 8-1. Pin Location

9. Typical Application PCB and Bonding

9.1 Typical Application PCB

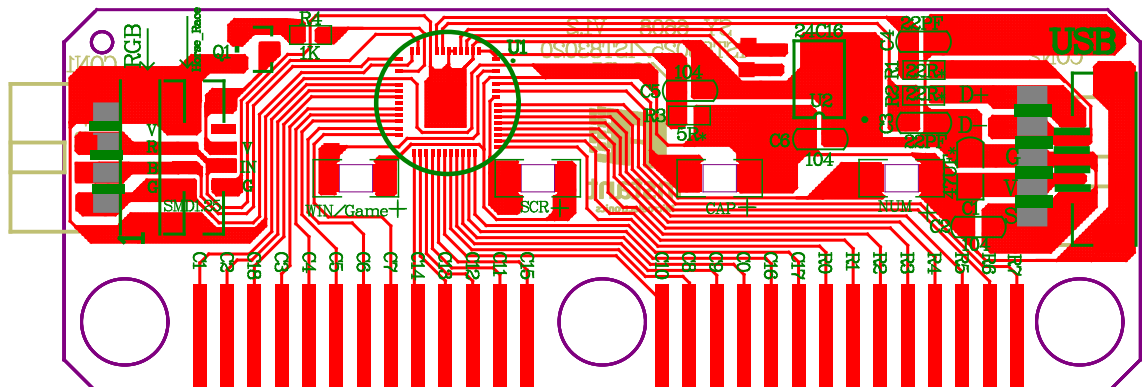

Figure 9-1 Typical Application PCB

10. Revision History

Version	Date	Reviser	Description
K201_Spec_EN.V1.00	2019/03/22	Jimmy	Create Preliminary Version