

Multi-mode multi-key multi-function series

A704E Datasheet

USB Optical Mouse

Version 1.00

Table of contents

1. General Description	1
2. Feature	1
3. Pin Assignment	2
4. Pin Description	3
5. Block Diagram	3
6. Application Note	4
6.1 Buttons Matrix definition	4
6.2 Multifunctional Key Instructions	4
6.3 Driver Mode	4
6.4 CPI setting	5
6.4.1 Gear and Number Settings	5
6.4.2 LED indication of gear	5
6.5 Backlight LED	5
6.5.1 Functional overview	5
6.5.2 Application Guideline	6
7. Electrical Characteristics	7
7.1 Absolute Maximum Rating	7
7.2 Recommend Operating Conditions	7
7.3 DC Electrical Characteristic (VDD = 5.0V, Temperature = 25°C)	7
7.4 AC Electrical Characteristic (VDD = 5.0V, Temperature = 25 °C)	8
8. Sensor Pixel Array Mapping	8
9. Typical Application Circuit	9
10. Package	10
11. Assembly Drawing	11
12. Revision History	11

1. General Description

Multi-mode multi-key multi-function mouse Sensor A704E is a high performance single chip CMOS process optical mouse sensor. This chip solution is used to implement a non-mechanical tracking engine for USB computer mouse.

A704E is based on algorithm which measures changes of sequential surface images and then determines the movement. It has the basic mouse function (R/M/L button, Y motion and Z axis wheel) and additional support for multimedia, games, Internet and office applications. It supports 4 level CPI resolutions (800/1200/1600/2400).

In the application of LED breathing mode, A704E has its own characteristics. On the basis of the commonly used functions of "circular discolored breathing" and "silent breathing", it introduces the function of "color-taking breathing" to provide users with more abundant application choices. From the point of view of user practicability, A704E uses function keys to realize the switching of three breathing modes

A704E is in a 14-pin optical DIP package. It has a built-in LED driver and internal oscillator to minimize the external components.

2. Feature

- Optical Navigation Technology,
- Compliant with USB2.0 and USB HID Specification V1.1.
- Support Winxp/Win2003/Win2008/Vista/Win7/Win8/Win10/Linux system, MAC OS, and Android system
- 5V Power Supply
- Internal crystal-less oscillator and on-chip LED Driver
- Adjustable four-level resolutions 800 (def)/1200/1600/2400 by CPI key
- Supporting single and double CPI mode
- Support 4 levels CPI light and shade indication of LED
- Supports 4-color breathing of two-color LED lamp, and changes breathing color with CPI switching
- With breathing mute function, LED breathing lamp can be switched on and off by 4th (or 5th) plus CPI/CPI-combination key
- Supporting 4-color circulatory discolored respiratory function
- All backlights support 4th(or 5th)+CPI combination key switch

- Supports three additional multi-function keys: Boss key, LED_MODE_SW key and Fire key (see Section 6.2 for details)
- Support L/M/R 3 buttons and X/Y/Z three axis
- Support the 4th/ 5th buttons
- IDIP-14 package and RoHS Compliant

3.Pin Assignment

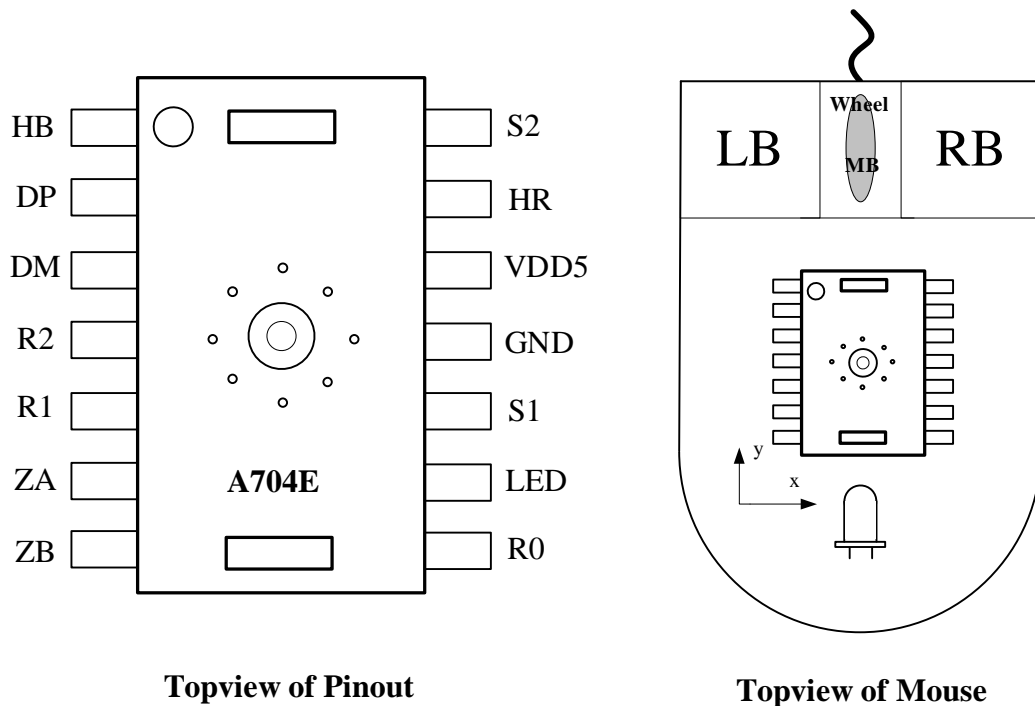

Figure 1. Pinout

4. Pin Description

	Pin Name	Type	Function Description
1	HB	OUT	Backlight LED output. Blue LED driver
2	DP	IN/OUT	USB D+
3	DM	IN/OUT	USB D-
4	R2	IN	Button array scan in, Single or double CPI select
5	R1	IN	Button array scan out
6	ZA	IN	Z axis in
7	ZB	IN	Z axis in
8	R0	IN	Button array scan in
9	LED	OUT	LED open drain output
10	S1	OUT	Button array scan out
11	GND	GND	GROUND
12	VDD5	POWER	Power 5v input
13	HR	OUT	Backlight LED output. Red LED driver
14	S2	OUT	Button array scan out

5. Block Diagram

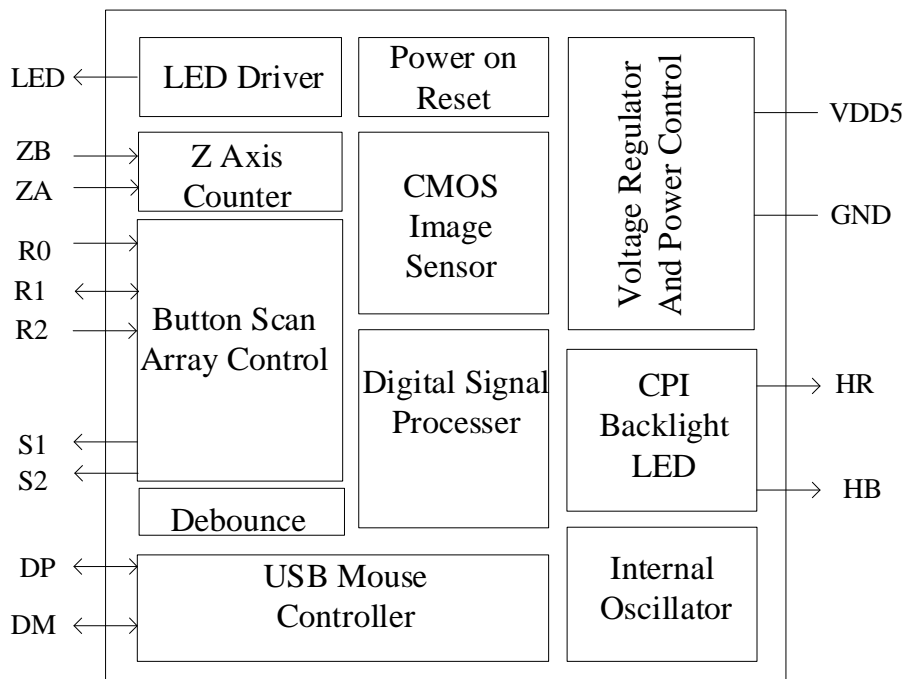

Figure 2. Block Diagram

6. Application Note

6.1 Buttons Matrix definition

Distribution of 9 physical keys in key array:

PIN	GND	S1	S2
R0	K1	K4	K7
R1	K2	K5	K8
R2	K3	K6	K9

	Normal mode		Multimedia mode	
	Single CPI	Double CPI	Single CPI	Double CPI
K1	L	L	L	L
K2	M	M	Play/pause	Play/pause
K3	R	R	R	R
K4	4 th (Backward)	4 th (Backward)	Next song (set)	Next song (set)
K5	5 th (Forward)	5 th (Forward)	Last song (set)	Last song (set)
K6	CPI	CPI-	CPI	CPI-
K7	BOSS	BOSS	BOSS	BOSS
K8	DOUBLE	CPI+	DOUBLE	CPI+
K9	FIRE	FIRE	FIRE	FIRE
Z1	Scroll up	Scroll up	Volume+	Volume+
Z2	Scroll Down	Scroll Down	Volume-	Volume-

Note: 1. When R2 has no pull-up resistance to power supply, the mouse is in single CPI mode. .
2. When R2 has pull-up resistance to power supply, the mouse is in dual CPI mode.

6.2 Multifunctional Key Instructions

Key Name	Function Description
BOSS	Used to switch the current application screen and desktop
DOUBLE	Pressing this button is equivalent to complete the double click operation.
FIRE	Pressing this button is equivalent to continuing to click the left button

6.3 Driver Mode

A704E supports the functional expansion of the driver mode. Through the driver provided, it can provide more rich functions and customized applications. See the driver Application Manual for details.

6.4 CPI setting

6.4.1 Gear and Number Settings

Out of the drive mode, A704E supports 4-speed resolution, defaulting to 1200. A704E supports two CPI switching modes:

- In Single CPI mode: It can be switched by single CPI button in the following order:
800(def)->1200->2000->2400->800
- In Double CPI mode: It can be switched to 2400 CPI by CPI+ key and 800 CPI by CPI- key

6.4.2 LED indication of gear

CPI	Two-color backlight breathing LED			Single-color indicator LED
	HR	HB	Color	Brightness
800	Off	On	Blue	Off
1200	On	On	Pink	Weak
1600	On	Off	Red	Middle
2400	On/2	On	Violet	Strong

Note: On/2: half of the normal brightness of the LED

There are two forms of CPI indication of A704E, namely "two-color backlight breathing LED" and "single-color indicator LED".

Monochrome LED indicates CPI gear according to brightness. While two-color backlight LED presses CPI switch key, the initial color corresponds to CPI gear one by one (see table above)

6.5 Backlight LED

6.5.1 Functional overview

In multimedia mode, the dual-color backlight LED has no breathing function, while the monochrome indicator LED starts breathing.

In normal mode, two-color backlight LED has three working modes.

Cyclic discoloration breathing: The default working mode of backlight LED is that two-color backlight LED breathes at a specific frequency. Its initial color corresponds to CPI gear one by one. After 6 seconds, it begins to cycle discoloration breathing according to the current color of blue, pink, red, purple and blue, providing a gorgeous visual effect.

Color-taking breathing: A704E puts forward the concept of "color-taking breathing". Users can "extract" one of the four circular colors according to their personal preferences through the LED_MODE_SW button, and breathe at a fixed frequency under this color.

Silence: In the color-taking breathing mode, press the LED_MODE_SW button and turn off the backlight.

Through side keys (4th or 5th) +CPI keys, users can switch the LED mode according to the sequence of "cyclic discolored breathing, color-taking breathing, mute breathing, cyclic discolored breathing". In addition, if the CPI is pressed for more than three seconds, the backlight can also be switched on and off..

6.5.2 Application Guideline

A704E backlight LED adopts common anode scheme. In addition to the default color matching methods in the function description table in Section 6.4, A704E also provides the following color matching methods:

If the base color is red and green (RG) LED, HR is connected to R, HB is connected to G, the corresponding 1200 CPI to 3200 CPI, the order of backlight color is green, yellow, red, light green.

Note: The default color matching method is adopted in application circuit of Section 9.

7. Electrical Characteristics

7.1 Absolute Maximum Rating

Parameters	Symbol	Min	Max	Unit	Notes
Supply Voltage	VDD	-0.5	5.5	V	
Operating Temperature	To	-15	55	°C	
Storage Temperature	Ts	-40	85	°C	
Lead Solder Temperature			260	°C	
Input Voltage	V _{in}	-0.5	5.5	V	
ESD	V _{ESD}	2		KV	All pins, Human Body Model

7.2 Recommend Operating Conditions

Parameter	Symbol	Min	Typical	Max	Units	Notes
Supply Voltage	VDD	4.5	5.0	5.5	V	
Operating Temperature	T _A	0	25	40	°C	
System Clock	CLK	22	24	26	MHz	
Speed	S	-	-	40	Inch/Sec	
Resolution	R	800	1200	2400	CPI	
Acceleration	A	-	-	10	G	
Frame Rate	Fr	-	-	4000	fps	
Distance from the Bottom of Lens to the Working Surface	Z	2.2	2.3	2.4	mm	

7.3 DC Electrical Characteristic (VDD = 5.0V, Temperature = 25°C)

Parameter	Condition	Symbol	Min	Typical	Max	Units	Note
Supply Current	In motion	I _{DD}	-	16.5	-	mA	
Supply Current	Static	I _{DD1}	-	7.8	-	mA	
Input Voltage High	Input port	V _{IH1}	2.0	-	-	V	
Input Voltage Low	Input port	V _{IL1}	-	-	0.8	V	
Input Voltage High	I/O port	V _{IH2}	2.0	-	-	V	
Input Voltage Low	I/O port	V _{IL2}	-	-	0.8	V	
Output Voltage High	I/O port	V _{OH1}	2.8	-	3.6	V	
Output Voltage Low	I/O port	V _{OL1}	0	-	0.3	V	

7.4 AC Electrical Characteristic (VDD = 5.0V, Temperature = 25 °C)

Parameter	Symbol	Min	Typical	Max	Units	Notes
Internal Ring Oscillator Frequency	F _{ROSC}		10		kHz	
Power-up Reset delay	T _{PU}	-	10	-	us	POR signal from 0 to 3.5
Debounce Time on Button	T _{DB}	9.5	11.5	13.5	ms	
Z-axis Sampling Time	T _Z	-	125	-	us	

8. Sensor Pixel Array Mapping

306	307	308	309	310	311	312	313	314	315	316	317	318	319	320	321	322	323
288	289	290	291	292	293	294	295	296	297	298	299	300	301	302	303	304	305
270	271	272	273	274	275	276	277	278	279	280	281	282	283	284	285	286	287
252	253	254	255	256	257	258	259	260	261	262	263	264	265	266	267	268	269
234	235	236	237	238	239	240	241	242	243	244	245	246	247	248	249	250	251
216	217	218	219	220	221	222	223	224	225	226	227	228	229	230	231	232	233
198	199	200	201	202	203	204	205	206	207	208	209	210	211	212	213	214	215
180	181	182	183	184	185	186	187	188	189	190	191	192	193	194	195	196	197
162	163	164	165	166	167	168	169	170	171	172	173	174	175	176	177	178	179
144	145	146	147	148	149	150	151	152	153	154	155	156	157	158	159	160	161
126	127	128	129	130	131	132	133	134	135	136	137	138	139	140	141	142	143
108	109	110	111	112	113	114	115	116	117	118	119	120	121	122	123	124	125
90	91	92	93	94	95	96	97	98	99	100	101	102	103	104	105	106	107
72	73	74	75	76	77	78	79	80	81	82	83	84	85	86	87	88	89
54	55	56	57	58	59	60	61	62	63	64	65	66	67	68	69	70	71
36	37	38	39	40	41	42	43	44	45	46	47	48	49	50	51	51	53
18	19	20	21	22	23	24	25	26	27	28	29	30	31	32	33	34	35
0	1	2	3	4	5	6	7	8	9	10	11	12	13	14	15	16	17

9. Typical Application Circuit

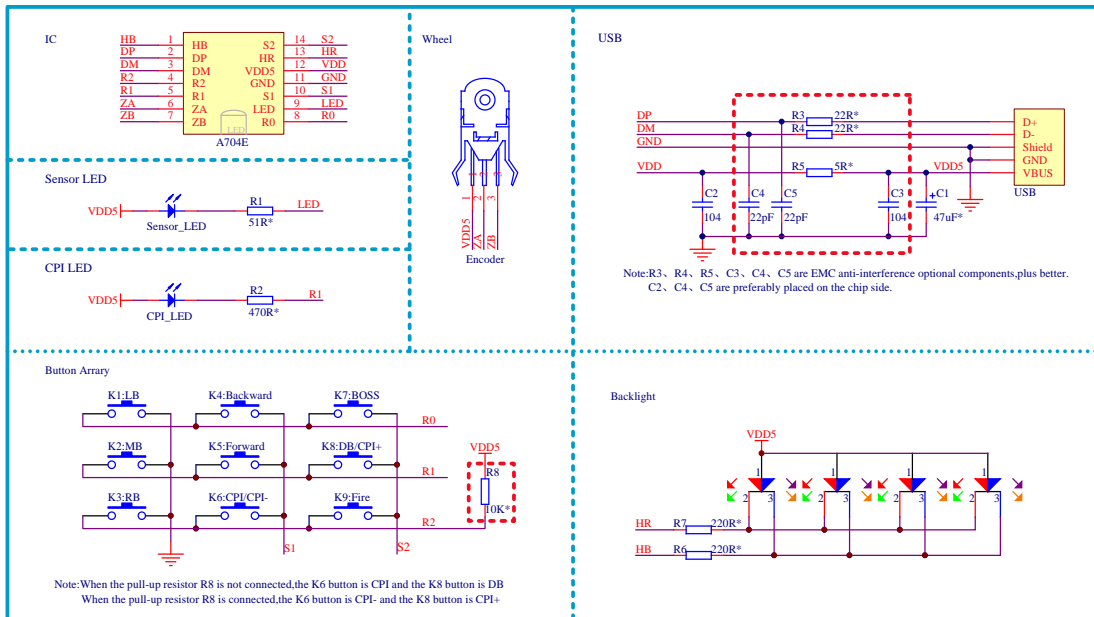

Figure 3. Application Circuit

10. Package

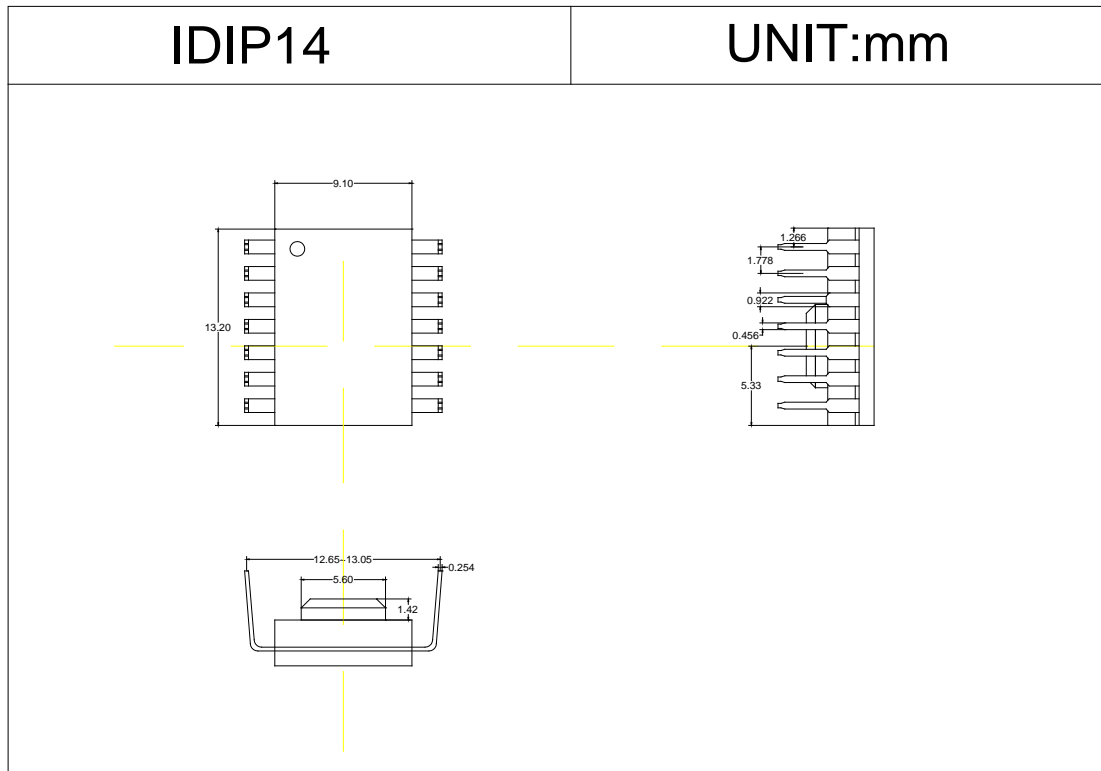

Figure 4. Package Outline Drawing

11. Assembly Drawing

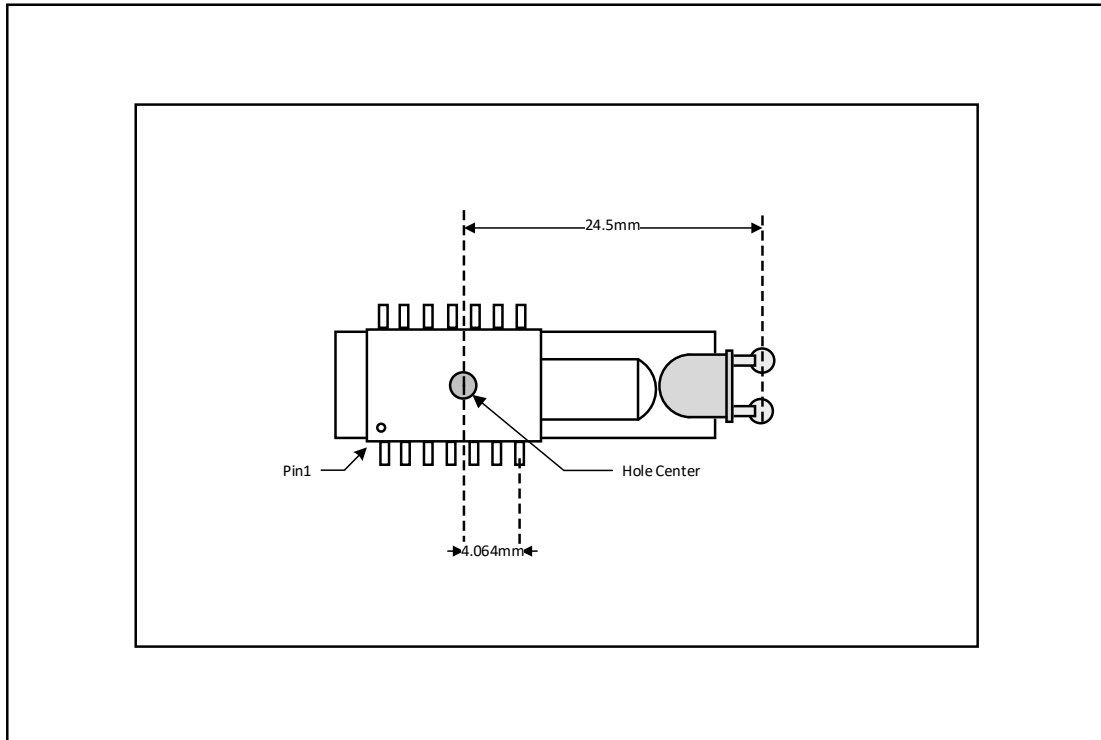

Figure 5. 2D Assembly drawing of A704E (Top and Side View)

12. Revision History

Version	Description	Date
A704E_SPEC_EN.V1.00	Create Preliminary Version	2019/07/18