

Multi-mode multi-key multi-function series

A601BS Datasheet

USB Optical Mouse

Version 1.00

Table of contents

1. General Description	1
2. Feature	1
3. Pin Assignment	2
4. Pin Description	2
5. Block Diagram	3
6. Application Note	3
6.1 Buttons Matrix definition	3
6.2 Multifunctional Key Instructions	4
6.3 Mode Switching	4
6.4 CPI Switching	4
6.5 CPI Indication	5
6.5.1 Function Description	5
6.5.2 Application Guidelines	5
7. Electrical Characteristics	6
7.1 Absolute Maximum Rating	6
7.2 Recommend Operating Conditions	6
7.3 DC Electrical Characteristic (VDD = 5.0V, Temperature = 25°C)	6
7.4 AC Electrical Characteristic (VDD = 5.0V, Temperature = 25 °C)	7
8. Sensor Pixel Array Mapping	7
9. Typical Application Circuit	8
10. Package	9
11. Assembly Drawing	10
12. Revision History	10

1. General Description

Multi-mode multi-key multi-function mouse Sensor A601BS is a high performance single chip CMOS process optical mouse sensor. This chip solution is used to implement a non-mechanical tracking engine for USB computer mouse.

A601BS is based on algorithm which measures changes of sequential surface images and then determines the movement. It is a 3D9K mouse chip has the basic mouse function (R/M/L button, Y motion and Z axis wheel) and additional support for multimedia, games, Internet and office applications. It supports 4 level CPI resolutions (800/1200/1600/2000). A601BS provides two application modes. It can switch between normal mode and multimedia mode freely by mode switch key, which provides convenience for users.

A601BS is in a 12-pin optical DIP package. It has a built-in LED driver and internal oscillator to minimize the external components.

2. Feature

- Optical Navigation Technology,
- Compliant with USB2.0 and USB HID Specification V1.1.
- Support Winxp/Win2003/Win2008/Vista/Win7/Win8/Win10/Linux system, MAC OS, and Android system
- 5V Power Supply
- Internal crystal-less oscillator and on-chip LED Driver
- Adjustable four-level resolutions 800/1200(def)/1600/2000 by CPI key
- Single and Double CPI Key Adjustment Mode Supporting CPI or CPI+/CPI-
- Support 4 levels CPI light and shade indication of LED
- Supports three additional multi-function keys: Boss key, Double-click key and Fire key (see Section 6.2 for details)
- Free switching between normal mode and multimedia mode (see Section 6.3 for details) by long press CPI key over 5s
- Support L/M/R 3 buttons and X/Y/Z three axis
- Support the 4th/ 5th buttons
- IDIP-12 package and RoHS Compliant

3. Pin Assignment

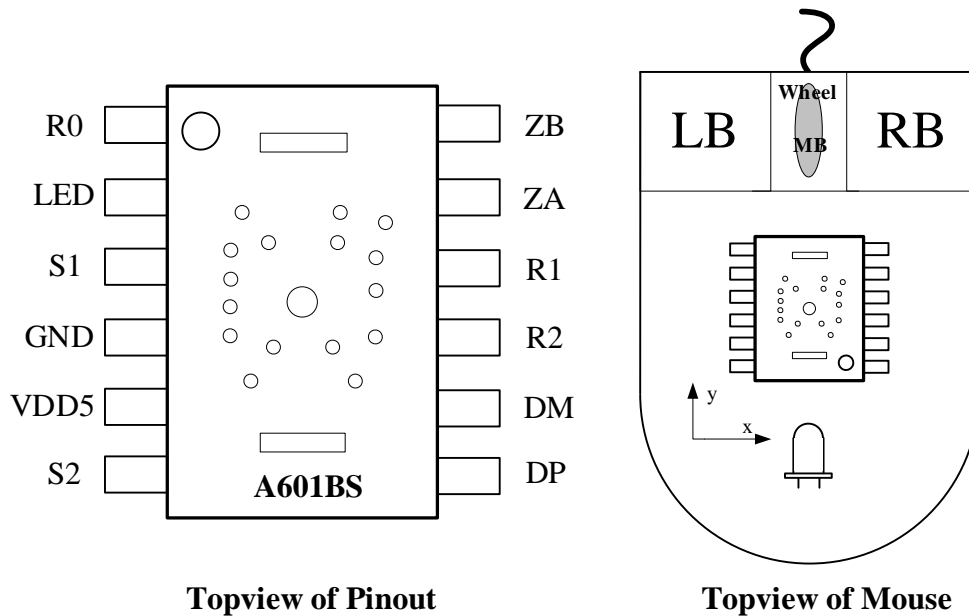

Figure 1. Pinout

4. Pin Description

	Pin Name	Type	Function Description
1	R0	IN	Button array scan in
2	LED	OUT	LED open drain output
3	S1	OUT	Button array scan out
4	GND	GND	GROUND
5	VDD5	POWER	Power 5v input
6	S2	OUT	Button array scan out
7	DP	IN/OUT	USB D+
8	DM	IN/OUT	USB D-
9	R2	IN	Button array scan in, Single or Double CPI Mode Selection
10	R1	IN	Button array scan in, CPI Single LED output
11	ZA	IN	Z axis in
12	ZB	IN	Z axis in

5. Block Diagram

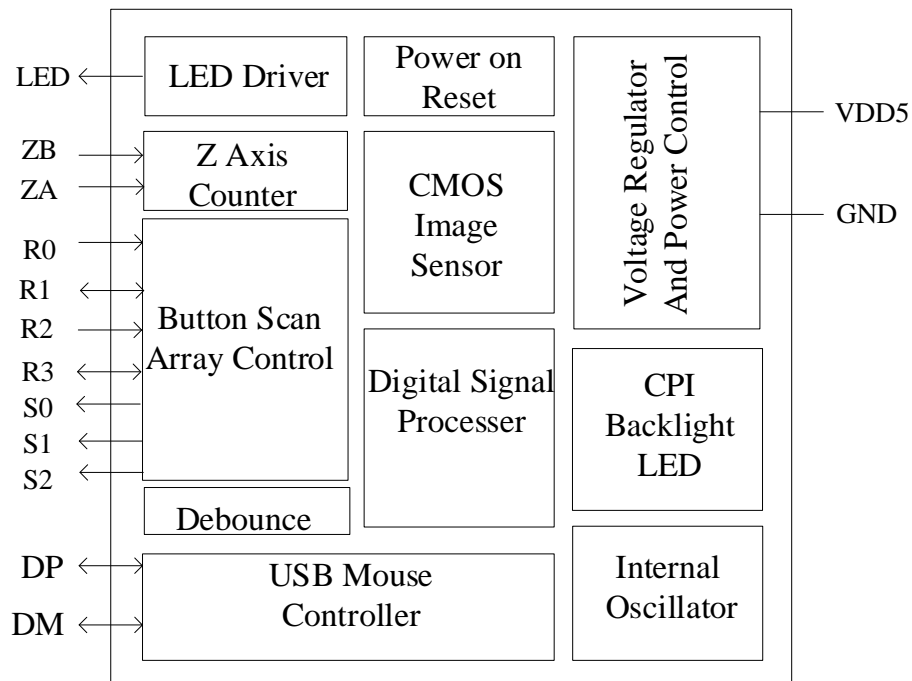

Figure 2. Block Diagram

6. Application Note

6.1 Buttons Matrix definition

Distribution of 9 physical keys in key array:

PIN	GND	S1	S2
R0	K1	K4	K7
R1	K2	K5	K8
R2	K3	K6	K9

	Normal mode		Multimedia mode	
	Single CPI	Double CPI	Single CPI	Double CPI
K1	L	L	L	L
K2	M	M	Play/pause	Play/pause
K3	R	R	R	R
K4	4 th (Backward)	4 th (Backward)	Next song (set)	Next song (set)
K5	5 th (Forward)	5 th (Forward)	Last song (set)	Last song (set)
K6	CPI	CPI-	CPI	CPI-
K7	BOSS	BOSS	BOSS	BOSS
K8	DOUBLE	CPI+	DOUBLE	CPI+
K9	FIRE	FIRE	FIRE	FIRE
Z1	Scroll up	Scroll up	Volume+	Volume+
Z2	Scroll Down	Scroll Down	Volume-	Volume-

Note: 1. When R2 has no pull-up resistance to power supply, the mouse is in single CPI mode. .
 2. When R2 has pull-up resistance to power supply, the mouse is in dual CPI mode.

6.2 Multifunctional Key Instructions

Key Name	Function Description
BOSS	Used to switch the current application screen and desktop
DOUBLE	Pressing this button is equivalent to complete the double click operation
FIRE	Pressing this button is equivalent to continuing to click the left button

6.3 Mode Switching

A601BS supports dual working mode: the default is normal mode. Switch to multimedia mode by pressing CPI (or CPI-) over 5s. After entering the multimedia mode, the monochrome LED begins to breathe. The same operation can be changed back to normal mode.

6.4 CPI Switching

A601BS supports four level resolutions. By default, 1200 CPI can be switched by single CPI button in the following order: 1200 (def) > 1600 > 2000 > 800 > 1200. If it is a double CPI button mode (CPI - / CPI +), it can be adjusted to 2000 CPI by CPI + button step by step, and to 800 CPI by CPI - button minimum.

6.5 CPI Indication

6.5.1 Function Description

CPI	Monochrome indication LED
	Brightness
800	Turn off
1200	Weak
1600	Middle
2000	Strong

In normal mode, monochrome LED indicates different CPI gears according to different brightness. After switching to multimedia mode, monochrome LED becomes breathing indicator.

In single CPI mode, every CPI button is operated, and the LED indicator lamp changes gear once. The change of gear is reflected by the brightness of the LED. The order is: weak (default) > medium > strong > Close > weak. In the dual CPI mode, the brightness of the LED decreases with the operation of CPI-keys until "off". In the operation of CPI+keys, the brightness of the LED increases until "strong" level.

6.5.2 Application Guidelines

- If the monochrome background lamp is used, in order to enhance the indication effect of CPI, it is suggested that the CPI indicator lamp should adopt a color with a larger color difference from the background
- To improve the indicator effect, CPI indicator lamps can be connected in parallel up to 4, surrounded by the mouse
- Background lamp can use colorful breathing lamp, up to four lamps can be added, surrounded by the mouse

7. Electrical Characteristics

7.1 Absolute Maximum Rating

Parameters	Symbol	Min	Max	Unit	Notes
Supply Voltage	VDD	-0.5	5.5	V	
Operating Temperature	To	-15	55	°C	
Storage Temperature	Ts	-40	85	°C	
Lead Solder Temperature			260	°C	
Input Voltage	V _{in}	-0.5	5.5	V	
ESD	V _{ESD}	2		KV	All pins, Human Body Model

7.2 Recommend Operating Conditions

Parameter	Symbol	Min	Typical	Max	Units	Notes
Supply Voltage	VDD	4.5	5.0	5.5	V	
Operating Temperature	T _A	0	25	40	°C	
System Clock	CLK	22	24	26	MHz	
Speed	S	-	-	40	Inch/Sec	
Resolution	R	800	1200	2400	CPI	
Acceleration	A	-	-	10	G	
Frame Rate	Fr	-	-	4000	fps	
Distance from the Bottom of Lens to the Working Surface	Z	2.2	2.3	2.4	mm	

7.3 DC Electrical Characteristic (VDD = 5.0V, Temperature = 25°C)

Parameter	Condition	Symbol	Min	Typical	Max	Units	Notes
Supply Current	In motion	I _{DD}	-	16.5	-	mA	
Supply Current	Static	I _{DD1}	-	7.8	-	mA	
Input Voltage High	Input port	V _{IH1}	2.0	-	-	V	
Input Voltage Low	Input port	V _{IL1}	-	-	0.8	V	
Input Voltage High	I/O port	V _{IH2}	2.0	-	-	V	
Input Voltage Low	I/O port	V _{IL2}	-	-	0.8	V	
Output Voltage High	I/O port	V _{OH1}	2.8	-	3.6	V	
Output Voltage Low	I/O port	V _{OL1}	0	-	0.3	V	

7.4 AC Electrical Characteristic (VDD = 5.0V, Temperature = 25 °C)

Parameter	Symbol	Min	Typical	Max	Units	Notes
Internal Ring Oscillator Frequency	F _{ROSC}		10		kHz	
Power-up Reset delay	T _{PU}	-	10	-	us	POR signal from 0 to 3.5
Debounce Time on Button	T _{DB}	9.5	11.5	13.5	ms	
Z-axis Sampling Time	T _Z	-	125	-	us	

8. Sensor Pixel Array Mapping

306	307	308	309	310	311	312	313	314	315	316	317	318	319	320	321	322	323
288	289	290	291	292	293	294	295	296	297	298	299	300	301	302	303	304	305
270	271	272	273	274	275	276	277	278	279	280	281	282	283	284	285	286	287
252	253	254	255	256	257	258	259	260	261	262	263	264	265	266	267	268	269
234	235	236	237	238	239	240	241	242	243	244	245	246	247	248	249	250	251
216	217	218	219	220	221	222	223	224	225	226	227	228	229	230	231	232	233
198	199	200	201	202	203	204	205	206	207	208	209	210	211	212	213	214	215
180	181	182	183	184	185	186	187	188	189	190	191	192	193	194	195	196	197
162	163	164	165	166	167	168	169	170	171	172	173	174	175	176	177	178	179
144	145	146	147	148	149	150	151	152	153	154	155	156	157	158	159	160	161
126	127	128	129	130	131	132	133	134	135	136	137	138	139	140	141	142	143
108	109	110	111	112	113	114	115	116	117	118	119	120	121	122	123	124	125
90	91	92	93	94	95	96	97	98	99	100	101	102	103	104	105	106	107
72	73	74	75	76	77	78	79	80	81	82	83	84	85	86	87	88	89
54	55	56	57	58	59	60	61	62	63	64	65	66	67	68	69	70	71
36	37	38	39	40	41	42	43	44	45	46	47	48	49	50	51	51	53
18	19	20	21	22	23	24	25	26	27	28	29	30	31	32	33	34	35
0	1	2	3	4	5	6	7	8	9	10	11	12	13	14	15	16	17

9. Typical Application Circuit

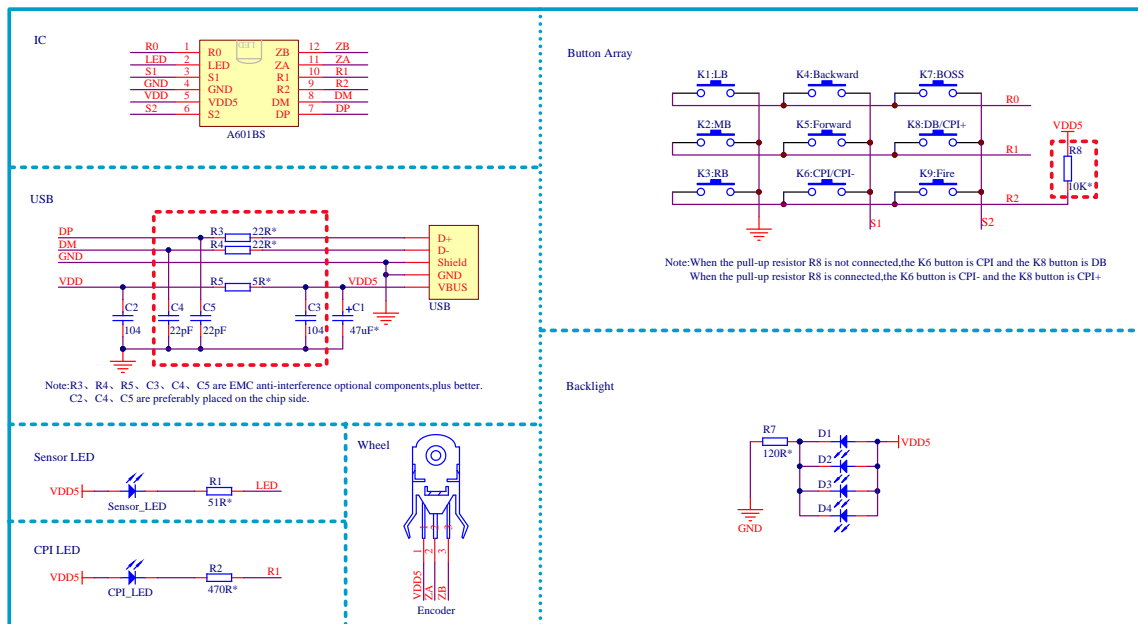

Figure 3. Application Circuit

10. Package

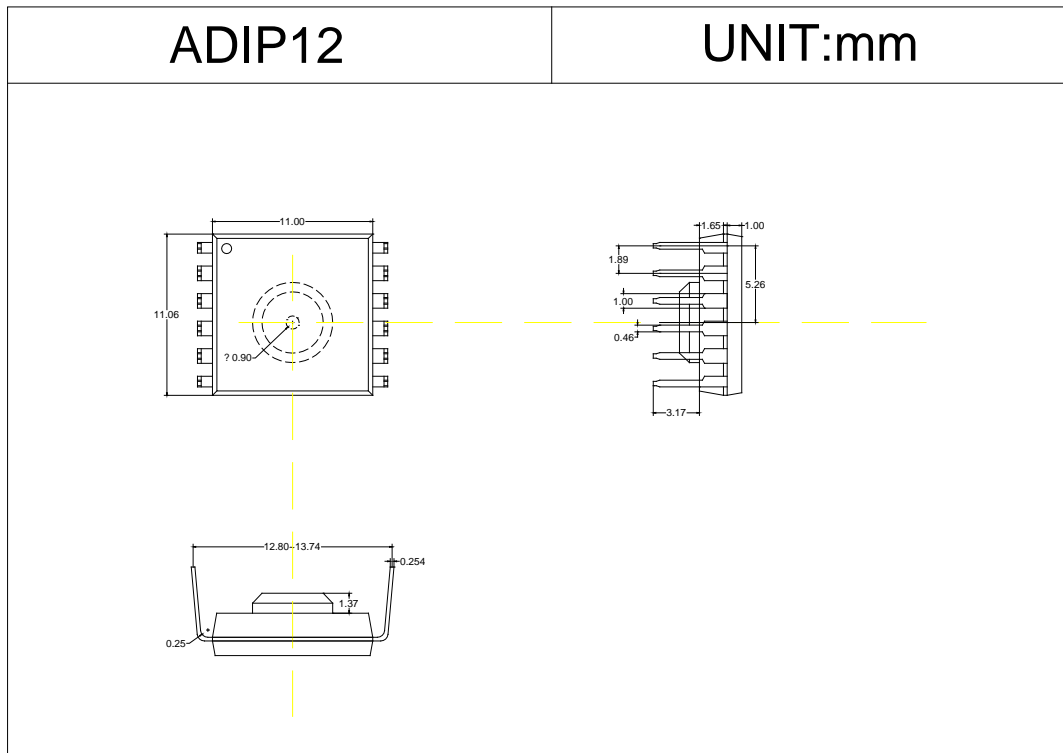

Figure 4. Package Outline Drawing

11. Assembly Drawing

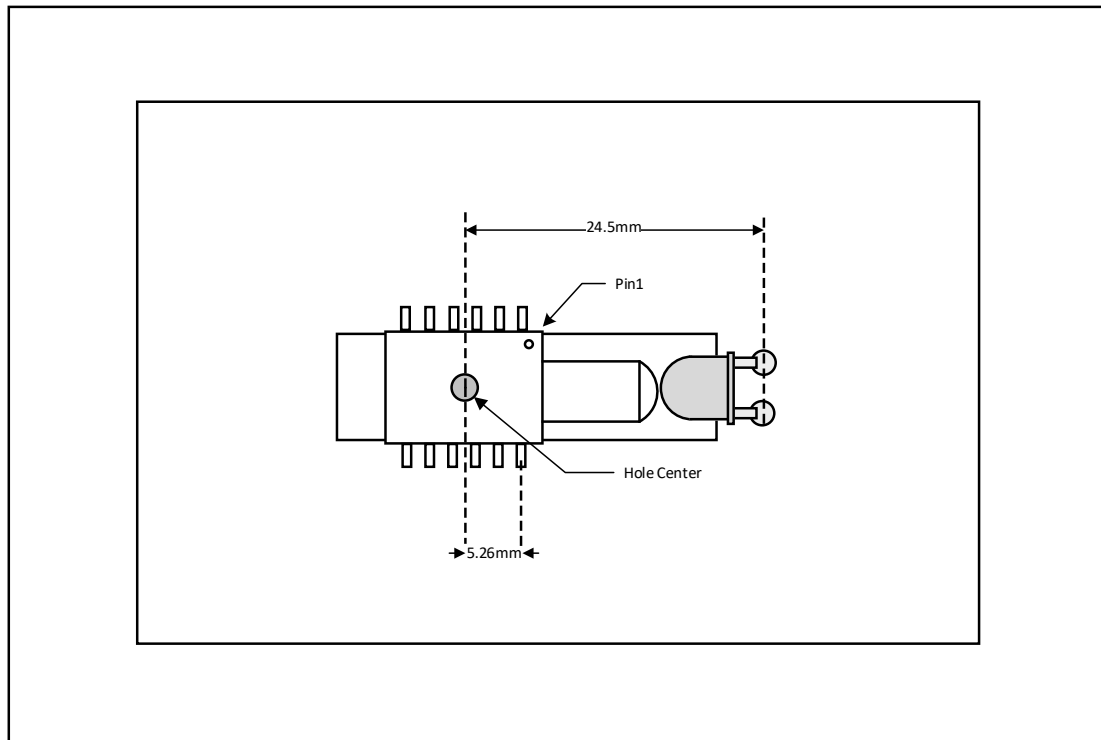

Figure 5. 2D Assembly drawing of A601BS (Top and Side View)

12. Revision History

Version	Description	Date
A601BS_SPEC_EN.V1.00	Create Preliminary Version	2019/07/18